

Status and new capabilities of the French Transportable Laser Ranging Station

F. Pierron¹, J. Nicolas¹, M. Kasser², J. Haase³

¹ Observatoire de la Côte d'Azur, Av. N. Copernic, F-06130 Grasse

² Ecole Supérieure des Géomètres et Topographes, 1 Bd. Pythagore, F-72000 Le Mans

³ ACRI, 260, Route du Pin Montard, F-06904 Sophia Antipolis

ABSTRACT

The French Transportable Laser Ranging Station is a very highly mobile SLR system unit (weighting 300 kg in 8 containers) with low operating costs. It was developed in the early 90's by the CNES, IGN and OCA/CERGA French organisms. The idea is to use a very small telescope (13 cm diameter) installed on a mount motorised with very high precision (a geodetic theodolite) allowing a small divergence laser beam. The laser is also very compact and the use of an avalanche photodiode makes the detection possible at a single photoelectron level. The one site installation of this new SLR system is very quick and its routine operation is quite automated.

The system has started its operational phase since late 1996. It can track satellites up to about 6000 km. The standard error of individual measurements was estimated of the order of 2-3 cm during a first observation campaign in Corsica between October 1996 and February 1997.

A description of the system is first given in this paper concerning the scientific objectives of such a mobile SLR station and its technical aspects. Then the current evolution and the future improvements are presented. These modifications were suggested by the probatory experiment in Corsica and were necessary for new applications as the time transfer by laser link (T2L2) experiment.

INTRODUCTION

The French Transportable Laser Ranging Station is a very highly mobile telemetry laser station dedicated to the tracking of satellites equipped with retroreflectors. The applications of such measurements are very numerous and include establishing terrestrial reference frames, determining Earth rotation parameters, measuring the Earth's gravity field, calibrating ocean altimetry. For accomplishing this, a world-wide international network is required. The number of satellite laser ranging (SLR) stations is about 40. They are quite different from one to another in terms of performance, and are mainly located in the Northern hemisphere. To compensate for this non optimal global distribution and to reach a certain number of scientific objectives, there are a few of mobile stations of about 1-3 tons (MTLRS-1 Germany, MTLRS-2 The Netherlands, TLRS USA, TIGO Germany) [Sperber et al., 1994], [Abele et al., 1994], [Sperber et al., 1996]. The French Transportable Laser Ranging Station (FTLRS) is by far the smallest one (weighting only 300 kg). Other stations are under development, notably the NASA SLR2000 project which concerns the construction of fully automated little stations with an eye-safe laser [Degnan et al., 1996].

In the past, these mobile stations were particularly useful in successfully reaching the objectives proposed in the framework of crustal dynamics programs [Bosworth et al., 1993; Wegener program (Vermaat et al., 1998)]. Recently the situation has changed with important results being obtained with the Global Positioning System (GPS) [Argus and Heflin, 1995] and the technique of Doppler Orbitography and Radiopositioning Integrated by Satellite (DORIS system) [Cazenave et al., 1993; Crétaux et al., 1999] in the field of reference frames, plate tectonic motion and crustal deformation. However, the satellite laser technique is the most straightforward in concept and is often better in terms of accuracy over very long periods of time (decades or more), especially in the vertical component, with targets having a quasi-infinite life. The use of several different techniques at a certain number of fundamental geodetic stations continues to be a key factor in increasing the absolute accuracy of these studies.

SLR also has important applications in the field of ocean altimetry where, for example, the absolute calibration of the altimeters over long periods necessary for fundamental research on sea level variations. New applications of the laser technique are appearing in the field of time transfer where SLR appears to be the most promising technique in terms of precision and accuracy [Samain and Fridelance, 1998].

Among these applications, the FTLRS (figure 1) was developed in order to be able facilitate the installation of a station at low cost nearly anywhere in the world, and also to participate in the calibration of altimetry radar satellites.



Figure 1 : The French Transportable Laser Ranging Station at Ajaccio (Corsica), 1996/1997.

TECHNICAL ASPECTS

The main features of the FTLRS are :

- A total weight of around 300 kg, including the carrying boxes of the equipment, in 8 containers with the heaviest one 55 kg
- Operational in a large number of climatic situations (-10°C to $+35^{\circ}\text{C}$, up to 95% humidity)
- A 100 ps, 100 mJ laser with a very low power consumption, able to accept any type of power supply, with low need for on-site maintenance
- The use of an avalanche diode used in Geiger mode, at a single photoelectron level
- A very small telescope, of 13 cm in useful diameter
- A mount based on a motorised electronic theodolite, stable during field operation, with very high precision (a few arc seconds of total error budget independent of the temperature and the field conditions)
- Quick installation (the system is operational within 24h) and routine operation as automated as possible.

The stations main components are the laser, the optico-mechanical telescope and mount, and the computer linked to the command electronic devices including the GPS clock, laser, mount, timing unit, and detector. The laser and the mount are the key features of the FTLRS. A synopsis is given in figure 2 and the various elements are described in the following paragraphs.

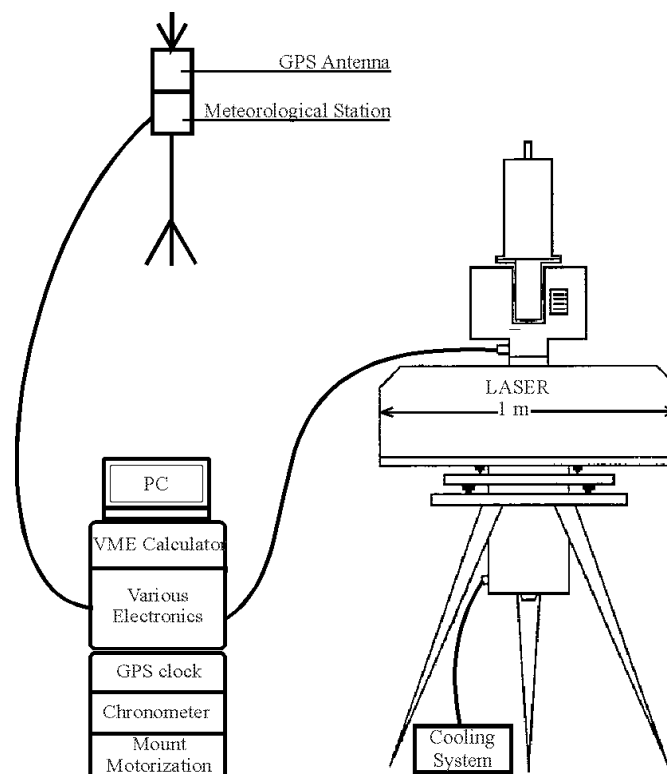

Figure 2 : Synopsis of the French Transportable Laser Ranging Station.

The laser

The laser is a compact Nd : YAG (total weight 80 kg in three parts), built by QUANTEL and partially transformed by the OCA/SLR team. It is a mode-locked laser, delivering 100 ps pulses at 10 Hz, with 100 mJ energy at 1.064 μm .

When the FTLRS project was initiated, it was proposed to work in two different wavelengths, the fundamental mode (IR) and the second harmonic (532 nm). After several campaigns using the IR mode, the green wavelength has been adopted because the detectors available at this wavelength are far better both in terms of quantum efficiency and transit time spread. The IR mode offers 4 times more photons and a much better atmospheric transmission, but these positive features are nearly completely counterbalanced by the diffraction of the corner cube retroreflectors on the satellites. Moreover, the green wavelength is also necessary for the Time Transfer by Laser Link (T2L2) experiment [Fridelance et al., 1997]. The detector used for this experiment was designed for the green wavelength which is in more common use than IR within the SLR community. As the main parts of the FTLRS optics are coated for these two colours, the only important change consisted of the insertion of a KDP (an anisotropic crystal) in the laser and a new detector.

The mechanical mount

The mechanical mount has been developed from a motorised modified KERN E2 high precision electronic theodolite. This field equipment has a demonstrated ability to keep its full precision (1.5 μrd) in any climatic conditions, with excellent specifications concerning resistance to shocks and vibrations. It has been modified to accept a heavier telescope (the optical part weights 9 kg). The motorization gives maximum angular speed of 20° by second, thus the orbital tracking is thus possible up to high elevation.

The mount is fixed directly on the laser bench, which itself is fixed on a special tripod. This one, although not very heavy (30 kg) is extremely stable, and it allows for (i) a fine centering over a ground mark and (ii) the exact levelling of the mount. Within the E2 theodolite, a standard and very convenient feature is the permanent monitoring of the tilt of the principal axis, allowing for efficient tracking even if some instabilities of the platform were to occur.

The optics

The optics allow the use of the same telescope (a 13 cm diameter SESO carbon fibre Cassegrain weighting 2 kg) for three functions : (i) emission of the laser, (ii) reception of the echo and (iii) visual tracking with a camera.

The laser is climbing into the Coudé path in circular polarisation, and a quarter wave plate transforms it to linear polarisation at its end. Then it is more than 99% reflected at a multilayer high energy Brewster plate that injects the pulse in the telescope, through a new quarter wave plate. The optical path is shown in figure 3.

When the echo goes back through the telescope, the transmission back through the quarter wave plate provides an elliptical polarisation, and part of it, generally more than 70% (it would be 100% for a reflection on a cube-corner retroreflectors (CCR) exactly orientated in the direction of the beam), reaches the detector through a narrow band (0.3 nm) interference filter.

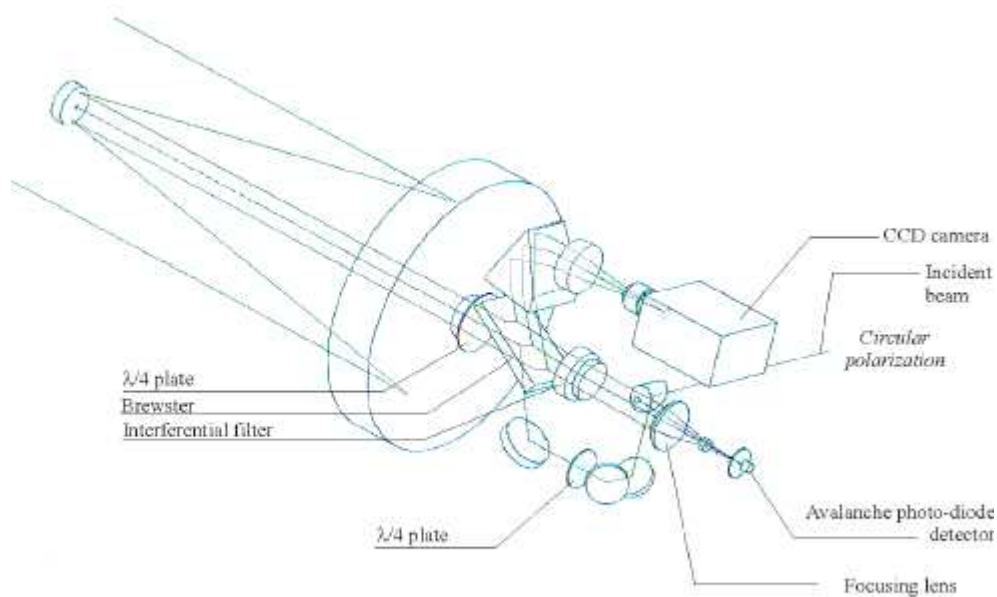

Figure 3 : Optic schema of the FTLRS mount

The atmosphere does not change too much the polarisation of the laser beam. The reflection over the CCR of the satellites have different consequences, depending on the incidence angle and generally the polarisation is more or less modified [Kasser and Goupil, 1996]. In fact the depolarisation depends on the kind of CCR. If the CCR are treated the light is poorly depolarised whereas if they are not the depolarisation is much more random. Most of the satellite CCR are treated except for LAGEOS 1 and 2.

The SSO-AD-230 detector is an avalanche photodiode working in Geiger mode. It is fixed in a small dry air chamber over a Peltier cooling device and its temperature is stabilised around -20°C . One reflection by the Brewster plate is used to divert a part of the light received towards a miniature CCD camera, that is withstanding without trouble the important parasitic light observed within the optics when the laser pulse is emitted. This camera lets the observer see the stars and the topographic details. It is employed for the initial orientation, the check of orientation on stars during operation and the line of sight at the reference ground target. All the electronic signals are transmitted through rotary contacts, even the detected signals : this situation is very favourable for the routine use because there is no cable behind the telescope.

The detection of the emission of the pulse is still provisional. It is performed with an ASGA photodiode, which presents a very stable response with a large dynamic range. It is located inside the laser bench. The difficulty of adjusting properly the energy level of the emitted pulse as it is seen by the APD has up to now prevented us from using the same detector for the emission and the reception. Some tests will be done in this last configuration.

For the Time Transfer by Laser Link (T2L2) experiment, a double reception optic was developed. A new module, attaching to fix an optic fiber in place of the detector was designed (without too much loss of telescope mobility). So, there are two working modes of the FTLRS. The first does classical satellite laser ranging with a single photoelectron avalanche photodiode (SPAD). With the second functioning mode one can do time transfer with multiphoton laser ranging, putting the light into an optic dating device. To pass from one operating mode to another, one must only change the focal instrument, and this operation and the optical adjustments require only half a day.

Timing unit

A highly stable GPS-controlled rubidium oscillator is used, within a TRAK system timing unit including a GPS receiver. This device provides GPS time within 100 ns, and therefore the timing in universal time of the echoes. The time-of-flight is measured with classical SLR means, consisting of a threshold discriminator (because of the non linearity of the detector) and a Stanford SR620 time counter/intervallometer whose accuracy is 10 ps.

Electronic circuits, hardware and software control

The automation of the FTLRS relies a VME 68060 computer operated under OS9 real-time operating system. The computer manages the timing unit, the intervallometer, the mount, the CCD camera, the laser (pulse energy, synchronisation), the meteorological unit, and the timing of the activation window of the APD. The high level commands are provided by a rugged portable PC with software which allows a completely automatic operation. It drives the acquisition of data, handles the CCD images, the graphical real time display, the pre-processing (acquisition, storage, emission), and the computation of normal points in a easy and handy way. This software was developed entirely at OCA. The links between the different components of the system are achieved by Ethernet/TCPIP connection network.

Tracking parameters (UTC, azimuth, electronic gate, time bias) can be adjusted in real time during the observation, increasing the efficiency of operations.

Improvements have already be done on the control system (up date of the control cards, new development of a real time system, addition of the local computer network functionality).

FUTURE EVOLUTION OF THE FTLRS

The main FTLRS improvements consist of essentially increasing its precision in order to reach the subcentimetric level. It is very important for the new oceanographic missions (Jason-1 and EnviSat both to be launched in 2000) which would realise sea level measurements more precisely. That's why the absolute calibration systems of the radar altimeters, including the FTLRS, have to be improved in order to be homogeneous and coherent with the other technical features.

The FTLRS improvements will concern the emission, reception and measurement systems. So it is related to optics, electronics, micro electronics and also changes in data processing, software and signal treatment. The use of only one detector for the start and the stop signals is under consideration, as it was already said. It may avoid some bias linked to the detector behaviour differences.

A comparative study with the SLR Grasse station will be carried out with collocations, comparisons of acquisition chains and results. A global error budget will also be realised. A very precise analysis of the error sources which occur in the scientific results obtained, without limiting to the instrumental sources (also for instance the signal propagation in the troposphere, the perturbations of the radar signals in the ionosphere...) will be taken into account.

Some progress will also be carried out on the FTLRS stability, to address a problem that appeared during a test campaign (calibration, possible bias from one pass to another) [Nicolas et al., 1998].

Another way of this instrument improvement concerns the automatic system of the satellite tracking which, so far, does not allow the tracking of the highest satellites. It was not possible to reduce easily the laser beam divergence, what is necessary to reach a satellite like Lageos. Now, as well known, Lageos plays a crucial role in the determining geodetic system. This question is under consideration notably in order to have a simple divergence adjustment system (which is easier in green than infrared wavelength). Echoes on Lageos on a routine basis are expected for a very next future.

Thus, improving the FTLRS performances and precision, it will make the FTLRS compatible with the space oceanographic future missions (Jason-1, EnviSat) and its scientific applications may be developed.

CONCLUSION

After the construction of the French Transportable Laser Ranging Station, a phase of tests, tuning, and adjustments of the different subsystems has been performed with terrestrial and satellite ranging. The tests have demonstrated that the laser behaviour regarding shocks and vibrations is fully satisfactory. The single photoelectron mode, with an avalanche photodiode in Geiger mode, provides good results, in close agreement with the preliminary energy balance computations. Concerning the tracking quality on distant satellites, some vibrations of the mount occur but with an amplitude lower than 5'' rms.

Then the station capability was tested during a real field experiment. This campaign was carried out from October 1996 to February 1997 near Ajaccio in the Corsica island (France) and is described in another paper of these proceedings [Nicolas et al., 1998]. The aim of this campaign of observation was also to participate to the absolute calibration of TOPEX/POSEIDON and ERS-2 radar altimeters. We can summarise the main results as follows. For 80% of the passes, the ranging accuracy is of about 2-3 cm. The station positioning can be achieved with an accuracy of about 2 cm (without Lageos observation and in agreement with other determination with GPS and DORIS). For the altimeter calibration, the error budget is of about 4 cm, including all the various sources of error.

The improvements are expected to significantly reduce the ranging accuracy to below 2 cm and increase the value of the FTLRS for the future calibration of Jason-1 and EnviSat (both to be launched in 2000).

An experiment of T2L2 [Fridelance et al., 1997] feasibility was carried out in June 1998 at the Observatory between the FTLRS and the Lunar Laser Ranging station. The results are good and confirm the possibility to use the FTLRS for the time transfer experiment scheduled for 2003 on the International Space Station. The accuracy should be of the order of 10-20 ps.

Currently some tests are done concerning the improvements explained in this paper before a new campaign of calibration in the late spring 1999.

ACKNOWLEDGEMENTS

The authors are grateful to the CNES (French Space Agency), the INSU (National Centre for Scientific Research in Astronomy and Earth Sciences), the IGN (National Geographic Institute) and the OCA (Côte d'Azur Observatory already in charge of the Grasse SLR and LLR stations) for the support and the development of the FTLRS.

Thanks are also due to the following groups. The technical realisation of various subsystems was performed at the OCA (electronics and software), CNES (optical subsystems behind the telescope), IGN (general conception and realisation of the tripod), SESO (telescope), KERN (motorised mount) and QUANTEL (laser).

We would also like to express our appreciation to the OCA/SLR team for the final assembly, test, checking and tuning.

We also want to thank C. Thom at LOEMI laboratory of IGN for having checked and modified the mount software.

REFERENCES

Abele M., Balodis J., Kalnis A., Rubans A., Vjaters J., West O., Zarinsh A. (1994) *Portable Satellite Laser Ranging System*, Proceedings of the 9th International Workshop on Laser Ranging Instrumentation, Camberra – Australia, 160-166

Argus D. and Heflin M. (1995) *Plate motion and crustal deformation estimated with geodetic data from the Global Positioning System*, Geophys. Res. Lett., 22, 1973-1976

Bosworth J., Coates R., Fischetti T., *The development of NASA's Crustal Dynamics Project*, Geodynamics Series, Volume 25, Contributions to Geodynamics : Technology, American Geophysical Union, 1-20

Cazenave A., Gegout P., Soudarin L., Dominh K., Barlier F., Exertier P., Boudon Y. (1993) *Geodetic results from Lageos 1 and DORIS satellite data*, Contributions of Space Geodesy to Geodynamics : Crustal Dynamics, Geodyn. Ser. Vol. 23, edited by D.E. Smith and D.L. Turcotte, AGU, Washington D.C., 81-98

Crétaux J.F, Soudarin L., Cazenave A., Bouillé F. (1999) *Present-day tectonic plate motions and crustal deformations from the DORIS space system*, J.G.R. (in press)

Degnan J. (1993) *Millimeter Accuracy Satellite Laser Ranging – A Review*, Geodynamics Series, Volume 25, Contributions to Geodynamics : Technology, American Geophysical Union, 133-162

Degnan J., McGarry J., Zagwodzki T., Titterton P., Sweeney H., Donovan H., Perry M., Conklin B., Decker W., Cheek J., Mallama A., Dunn P., Ricklefs R. (1996) *SLR2000 : An Inexpensive, Fully Automated, Eyesafe Satellite Laser Ranging System*, Proceedings of the 10th International Workshop on Laser Ranging Instrumentation, Shanghai – China, 367-377

Fridelance P., Samain E., Veillet C. (1997) *T2L2 – Time Transfer by Laser Link : a new optical time transfer generation*, Exp. Astron. 7, 193-207

Herring T., Pearlman M. (1993) *Future developments and Synergism of Space Geodetic Measurement Techniques*, Geodynamics Series, Volume 25, Contributions to Geodynamics : Technology, American Geophysical Union, 21-25

Kasser M., Goupil B. (1996) *The polarisation behaviour of cube corner retroreflectors used in SLR satellites*, Proceedings of the 10th International Workshop on Laser Ranging Instrumentation, Shanghai – China, 263-268

Perosanz F., Marty J.C., Balmino G. (1997) *Dynamic orbit determination and gravity field model improvement from GPS, DORIS and Laser Measurements on TOPEX/POSEIDON satellite*, Journal of Geodesy, volume 71 Issue 3, 160-170

Samain E. and Fridelance P. (1998) *Time Transfer by Laser Link (T2L2) experiment on Mir*, metrologia, 35, 151-159

Sperber P., Motz R., Schotz P., Marebby M., Zane R. (1994) *Test and developments at the MTLRS-1 receiving system*, Proceedings of the 9th International Workshop on Laser Ranging Instrumentation, Canberra – Australia, 400-406

Sperber P., Boer A., Dassing R., Hase H., Schlueter W., Kilger R. (1996) *TIGO – Project : concept – Status – Plans*, Proceedings of the 10th International Workshop on Laser Ranging Instrumentation, Shanghai - China, 135-144

Vermaat E., Degnan J., Dunn P., Noomen R., Sinclair A. (1998) *Satellite Laser Ranging, status and impact for Wegener*, J. Geodynamics, Vol. 25, N°. 314, 195-212